

General Specifications

GS 05G01B12-01E

Model LL100
PC-based Parameters
Setting Tool
(with Multi-monitoring Function)



■ General

The LL100 PC-based Parameters Setting Tool is a software package used to set the setup parameters, operating parameters, and program patterns* of the GREEN Series controllers from a personal computer. This tool allows users to download, upload, print out parameters, and display PV trend data during PID tuning, etc.

The multi-monitoring function can detect two or more controllers automatically, and can display or save trend data like PV, etc.

*: For program controllers only.

■ Parameters (Program) Setting Functions

Sets and changes the controller's parameters such as the controller mode (UT/UP mode), universal input/output selection, setup parameters, operating parameters, and program pattern parameters* (program/start conditions and patterns).

Note: Uploading/downloading/comparing parameters via Ethernet is impossible for the controller operated by custom computation function (UT mode 21 or UP mode 21). Use front communication or serial terminal communication.

*: For program controllers only.

Tuning Function:

This function is used to tune the PID parameters of the controllers. The PID parameters can be tuned and the auto-tuning function can be executed while the trend graphs of PV, SP, and control output are being displayed on a personal computer screen.

Downloading, Uploading, and Comparing Parameters:

When the controller operation is stopped, users can download the created parameter data to the controller and upload the parameter data from the controller. It is also possible to compare the parameter data created using this tool with the data in the controller.

File Management Function:

This function allows users to save the parameter data created using this tool and those uploaded from the controller to the hard disk of a personal computer or a floppy disk. It is also possible to compare the parameter data created using this tool with those in the parameter files created in the past.

Printout Function:

Parameter data can be printed out from a printer connected to a personal computer.

■ Multi-monitoring Function

This function allows users to display and collect PV, SP, control output and alarm generating state as trend data. It is possible to detect two or more controllers (a maximum of 16 loops) connected to the personal computer automatically, and to display trend graphs on a personal computer screen.

Tuning Function:

This function is used to tune the PID parameters of the controller. The PID parameters can be tuned, the auto-tuning function can be executed for every connection loop and an operating mode can be changed while the trend graphs of PV, SP and control output are being displayed on a personal computer screen.

File Management Function:

The trend data collected by the monitoring function can be saved as a CSV format so that commercial spreadsheet software like Microsoft Excel can treat data. The saved trend data can be read and displayed as trend graph.

■ Parameter Setting Function for Ethernet Converter

Sets the parameters related to the Ethernet communication function of the Ethernet/RS485 converter, VJET.

■ Applicable Controllers

- UT750 Digital Indicating Controller
- UT551 Digital Indicating Controller
- UT551-xA to xD Digital Indicating Controller
- UT550/520 Digital Indicating Controller
- UT450/420 Digital Indicating Controller
- UT351/321 Digital Indicating Controller
- UT351-xA Digital Indicating Controller
- UT350/320 Digital Indicating Controller
- UP750 Program Controller
- UP550 Program Controller
- UP351 Program Controller
- UP350 Program Controller

■ Functions Restricted by Communication Method

| Function | Communication method | | |
|---------------------------|----------------------|-------------------------------|------------------------|
| | Front communication | Serial terminal communication | Ethernet communication |
| Parameter setting | ✓ | ✓ | Cond. |
| Program pattern setting | ✓ | ✓ | Cond. |
| Multi-monitoring function | ✓ | ✓ | ✓ |

✓: Available.

Cond.: Not available when operated by custom computation function (UT mode 21 or UP mode 21).

■ Connection between the Controller and a Personal Computer

[Via Dedicated Adapter]

By attaching a dedicated adapter to the controller's front panel, users can upload and download parameter data to and from a personal computer.

To communicate via the dedicated adapter:

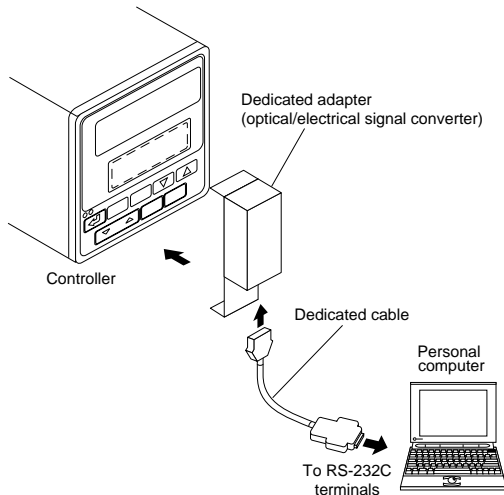

[Via RS-485 Communication Terminals]

Users can also upload and download parameter data to and from a personal computer via the rear communication terminals of the controller. This connection requires an RS-232C/RS-485 converter (ML2).

To communicate via the communication terminals:

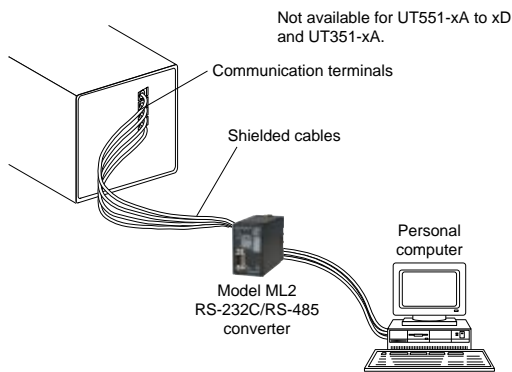

[Via Ethernet Communication Terminal]

The UT351-xA/UT551-xA to xD controllers can communicate with a personal computer via the Ethernet communication terminal. Connect a personal computer and a communication network using a cable that meets the 10BASE-T/100BASE-TX standards. Also, the UT351-xA/UT551-xA to xD controllers and VJET converter can use the Ethernet-serial gateway function to communicate with the GREEN Series controllers equipped with the communication functions via network. In this case, cross-connect the rear communication terminals of the UT351-xA/UT551-xA to xD/VJET and of the GREEN Series controllers.

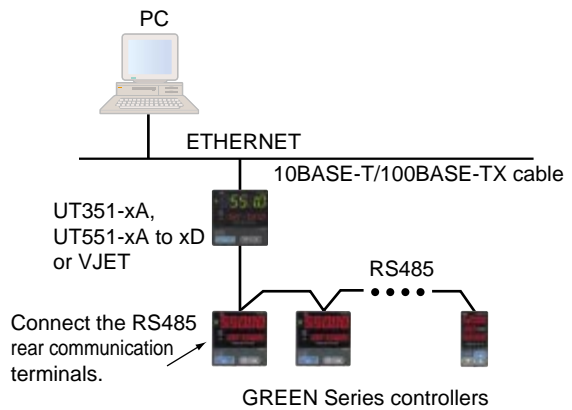

■ Operating Environment

Personal Computer:

- An IBM PC/AT compatible computer with either Microsoft Windows 98/2000/XP or Windows NT 4.0 operating software.
- OS: Microsoft Windows 98/2000(Professional)/XP(Home Edition/Professional) or Windows NT 4.0(Service pack 3 or later)
- CPU: Pentium processor of 300MHz or faster is recommended.
- Main memory: 128 MB or more is recommended for Windows 98/2000/XP
24 MB or more is recommended for Windows NT 4.0
- Hard disk: 10 MB for tool program storage
2 MB or more for parameter data storage
- CRT: 800 × 600 pixels or more
Font: Small font
Color: 256 colors or more
- RS-232C communication port: 1 channel
- Network: 10BASE-T/100BASE-TX (needed for the communication via Ethernet)
- 3.5-inch floppy disk drive: 1 (needed for installation)
- Printer: Needed for printing
A4-size printer, compatible with Windows 98/2000/XP or Windows NT 4.0

Dedicated Adapter

- Communication system: Non-contact, bi-directional, optical serial communication (on controller side)
RS-232C half-duplex; a dedicated cable is used (on PC side)
- Power supply: Two JIS SM-4 (size AAA) batteries, or an external power supply
An external power supply is recommended if the tuning view is to be used for a prolonged period.
- Battery life: About 50 hours (using alkaline batteries when the tuning view is displayed.)
- External power supply: Conforming to EIAJ RC-6705
Input rate: 5 V DC, 50 mA
(Requires a commercial external power supply plug and AC adapter to be purchased separately.)
- Ambient temperature: 0 to 50°C
- Ambient humidity: 20 to 90% RH (no condensation)
- Transit/storage conditions: -25 to 70°C, 5 to 90% RH (no condensation)
- Construction: Neither dust-proof nor water-proof
- Conformity to standard: CE marking approved (EMC only)

Dedicated Cable

- 9-pin, D-sub cable for IBM PC/AT compatible machine
- Cable length: 3 m

■ Packaged Contents

- Software supplied :3.5-inch, 2HD, 1.44 MB floppy disks (4 disks)
- Dedicated cable and adapter:
1 set for connecting a personal computer to the optical communication port in the controller's front.
- User's manual: User's Manual -Reference- (CD-ROM version)

■ External Dimensions

Dedicated Adapter

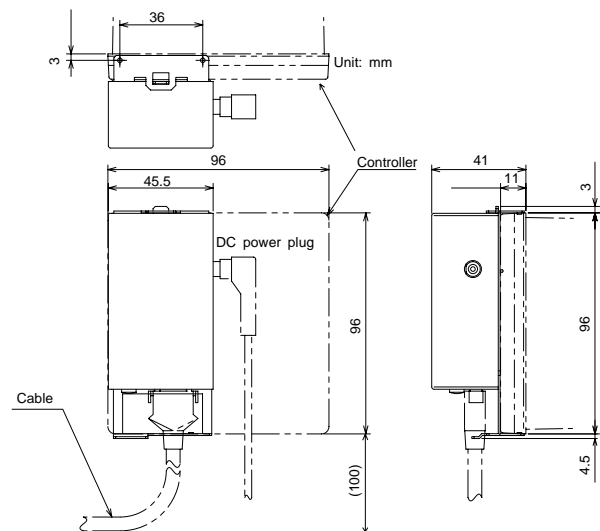

Dedicated Cable

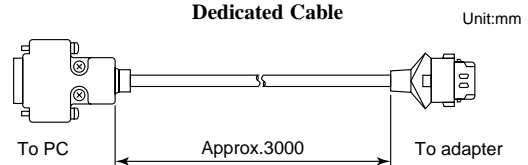

External Power Supply Inlet of Dedicated Adapter

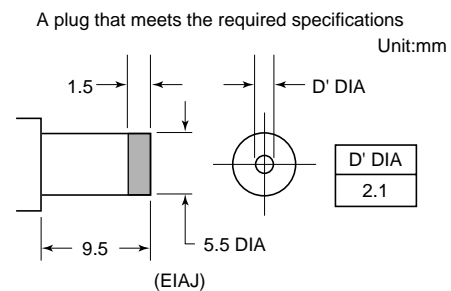

■ Model and Suffix Codes

| Model | Suffix code | Description |
|-------|-------------|-----------------------------------|
| LL100 | | PC-Based Parameters Setting Tool |
| | -E10 | For IBM PC/AT compatible computer |

Trademarks

- Windows 98/2000/XP and Windows NT 4.0 are registered trademarks of Microsoft Corporation, U.S.A.
- Other proper nouns such as trade names and company names are trademarks or registered trademarks of their respective companies.
- “Ethernet” is registered trademark of XEROX Corporation.